

5. USE #10 X 100° FLAT HEAD HARDWARE TO MOUNT THROUGH THE CHASSIS MEMBER.
4. GUIDE FEATURES QUICK DISCONNECT OF THE CHASSIS MEMBER. CHASSIS MEMBER ON GUIDES WITHOUT A STOP OPEN "S" FEATURE ARE FREE TO REMOVE FROM CABINET SECTION.
3. GUIDE IS NON-HANDED, MAY BE USED AS A LEFT OR RIGHT HAND MOUNTING UNIT.
2. FINISH: CHANNELS AND ALUMINUM COMPONENTS ARE ANNOZINED PER MIL-A-8625, TYPE II, CLASS 1, CRES PARTS ARE PASSIVATED PER SAE-AMS-2700.
1. MATERIAL: CHANNELS: HIGH STRENGTH ALUMINUM ALLOYS WITH TENSILE STRENGTH OF 35,000 PSI PER ASTM B221, COMPONENTS: CRES AND HIGH STRENGTH ALUMINUM ALLOYS.

GUIDE	GUIDE WITH ADJUSTABLE REAR SHOCK BLOCK	STOP LOCATION	LENGTH	CHASSIS LENGTH	MOUNTING HOLE PATTERN				REAR BRACKET ADJUSTMENT	GUIDE WEIGHT (LBS/EACH)
					A	B	C	D		
TIG2U-280-14	TIG2U-280A-14	NO STOP	14.00	14.00	6.000	10.000	12.000	-	11.00 TO 19.00 INCHES	1.34
TIG2U-280S-14	TIG2U-280SA-14	9.00								
TIG2U-280-16	TIG2U-280A-16	NO STOP	16.00	16.00	8.000	12.000	14.000	8.000	13.00 TO 21.00 INCHES	1.47
TIG2U-280S-16	TIG2U-280SA-16	10.00								
TIG2U-280-18	TIG2U-280A-18	NO STOP	18.00	18.00	8.000	12.000	16.000	8.000	15.00 TO 23.00 INCHES	1.61
TIG2U-280S-18	TIG2U-280SA-18	11.00								
TIG2U-280-20	TIG2U-280A-20	NO STOP	20.00	20.00	10.000	14.000	18.000	18.000	17.00 TO 25.00 INCHES	1.74
TIG2U-280S-20	TIG2U-28SA-20	12.00								
TIG2U-280-22	TIG2U-280A-22	NO STOP	22.00	22.00	10.000	14.000	20.000	20.000	19.00 TO 27.00 INCHES	1.88
TIG2U-280S-22	TIG2U-280SA-22	13.00								
TIG2U-280-24	TIG2U-280A-24	NO STOP	24.00	24.00	12.000	16.000	22.000	22.000	21.00 TO 29.00 INCHES	2.01
TIG2U-280S-24	TIG2U-280SA-24	14.00								
TIG2U-280-26	TIG2U-280A-26	NO STOP	26.00	26.00	14.000	18.000	24.000	24.000	23.00 TO 31.00 INCHES	2.14
TIG2U-280S-26	TIG2U-280SA-26	16.00								
TIG2U-280-28	TIG2U-280A-28	NO STOP	28.00	28.00	14.000	18.000	26.000	26.000	25.00 TO 33.00 INCHES	2.28
TIG2U-280S-28	TIG2U-280SA-28	17.00								
TIG2U-280-30	TIG2U-280A-30	NO STOP	30.00	30.00	16.000	20.000	28.000	24.000	27.00 TO 35.00 INCHES	2.41
TIG2U-280S-30	TIG2U-280SA-30	18.00								
TIG2U-280-32	TIG2U-280A-32	NO STOP	32.00	32.00	16.000	20.000	30.000	30.000	29.00 TO 37.00 INCHES	2.55
TIG2U-280S-32	TIG2U-280SA-32	19.00								
TIG2U-280-34	TIG2U-280A-34	NO STOP	34.00	34.00	18.000	22.000	32.000	32.000	31.00 TO 39.00 INCHES	2.68
TIG2U-280S-34	TIG2U-280SA-34	20.00								
TIG2U-280-36	TIG2U-280A-36	NO STOP	36.00	36.00	18.000	22.000	34.000	34.000	33.00 TO 41.00 INCHES	2.81
TIG2U-280S-36	TIG2U-280SA-36	21.00								

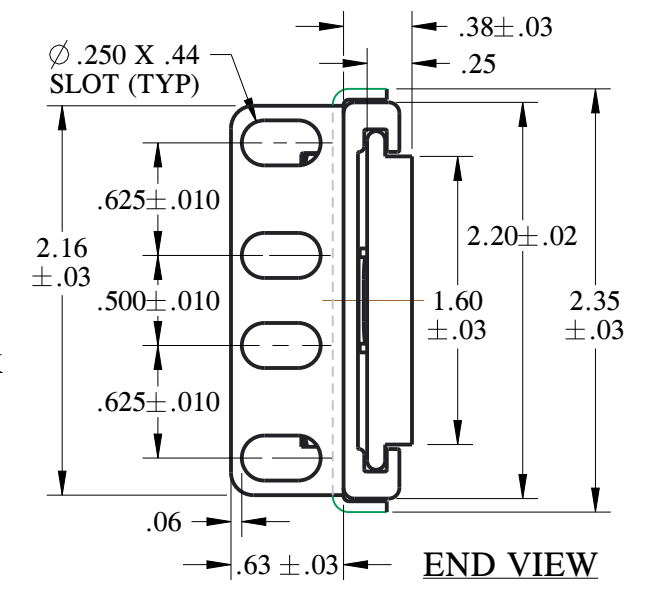
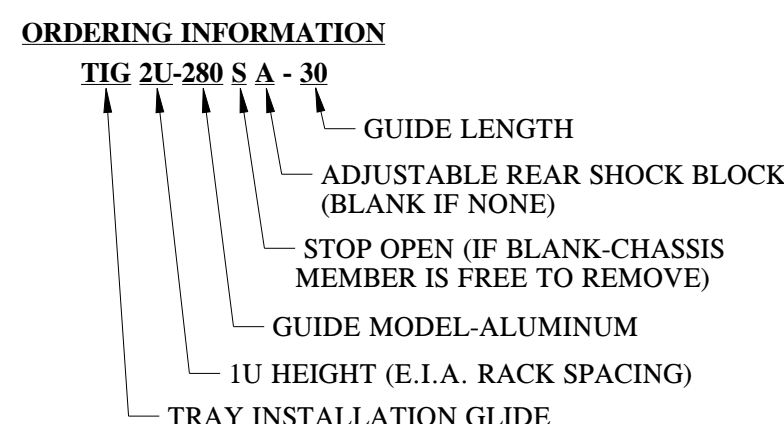

Irvine Technology Center
 250 Commerce, Suite 100
 Irvine, CA 92602
 Tel. (714) 665-4400
 Fax: (714) 368-7002
 Website: www.jonathanengr.com
 Engineer - Production - Integration/ Subassembly - Logistics
 United States - Mexico - China - Taiwan

TOLERANCES UNLESS OTHERWISE NOTED				PART NUMBER : TIG2U-280	DESCRIPTION : TRAY 2U INSTALLATION GUIDE
.XX	.XXX	ANGLES	HOLES	DATE : 05/17/18	COPYRIGHT © 2012 JONATHAN ENGINEERED SOLUTIONS
± .01	± .005	± 1°	± .005	SHEET 1 OF 2	

GUIDE INSTALLATION:

STEP 1:

REMOVE CHASSIS MEMBERS FROM GUIDES.

ATTACH THE CHASSIS MEMBERS TO THE CHASSIS USING #10 X 100° FLAT HEAD MACHINE SCREWS.

USING 2 TO 4 INCH SPACING BETWEEN MOUNTING HARDWARD.

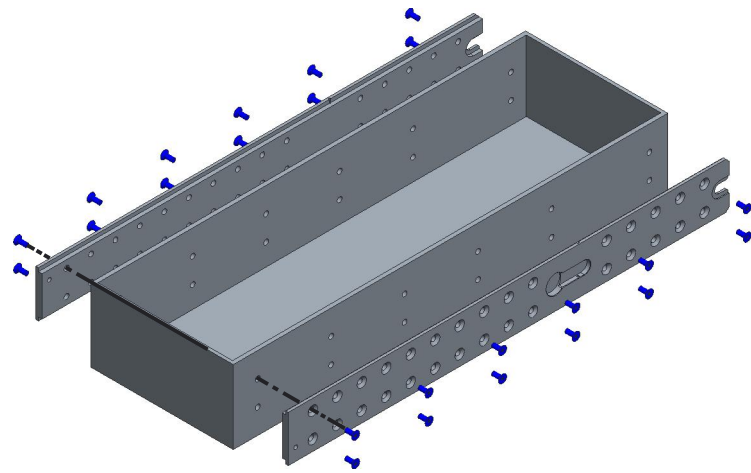

STEP 2:

INSTALL OF THE CABINET MEMBERS.

ADJUST THE REAR BRACKET TO FIT THE RAIL TO RAIL DEPTH OF THE EIA RACK.

MOUNT THE CABINET MEMBERS INTO THE EIA RACK USING ALL MOUNTING LOCATIONS ON THE BRACKET'S EIA MOUNTING FLANGES.

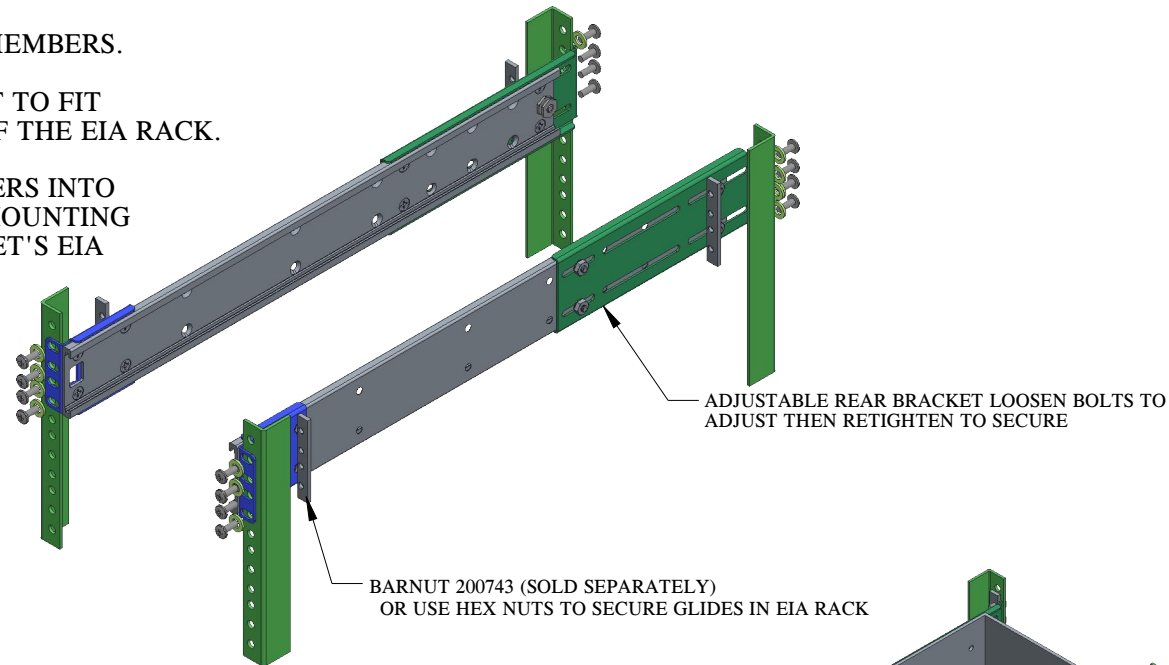

STEP 3:

* SLIDE THE CHASSIS INTO THE GUIDES (ALREADY INSTALLED IN THE EIA RACK).

* FULLY CLOSE THE CHASSIS TO THE STOWED POSITION.

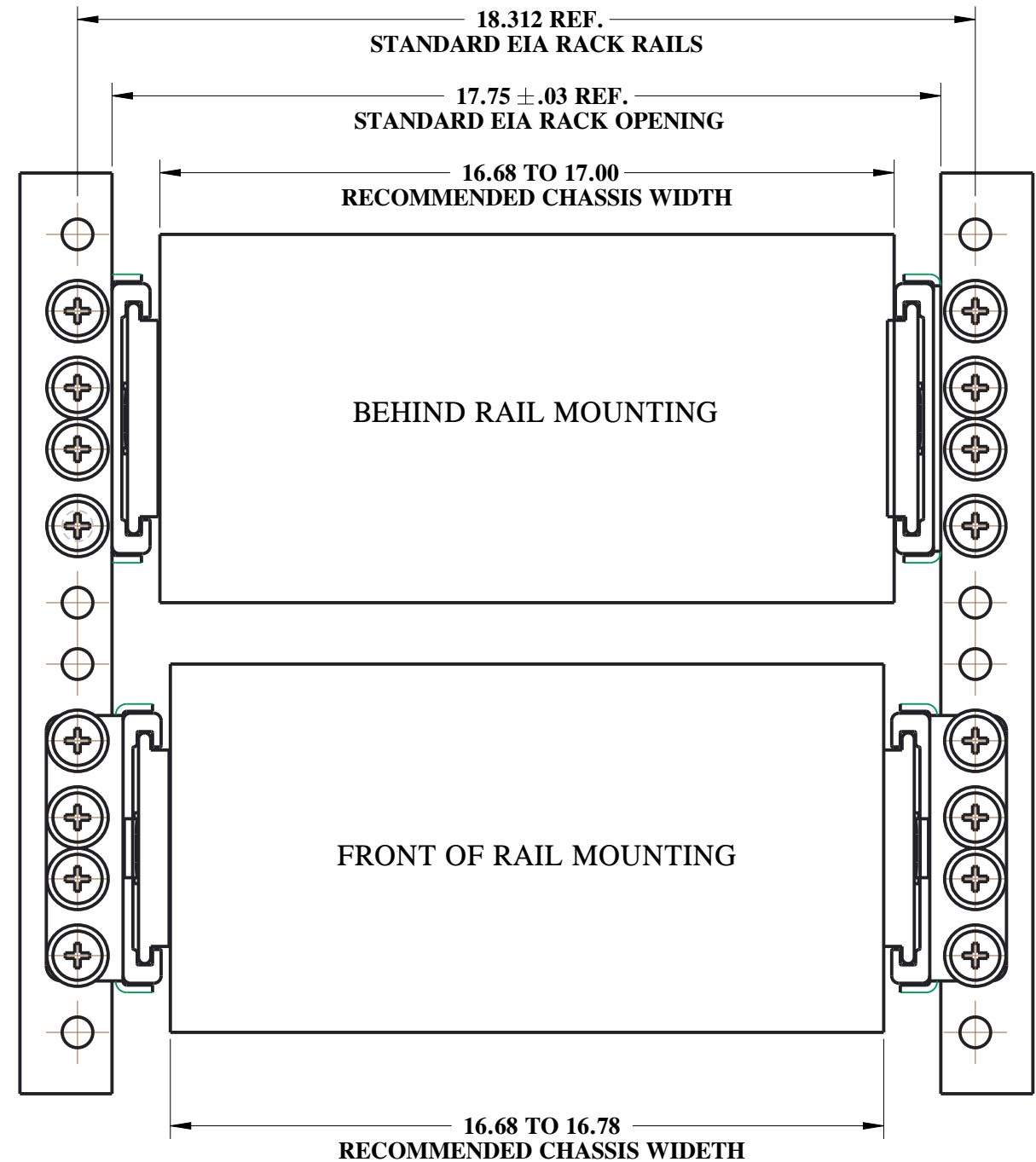
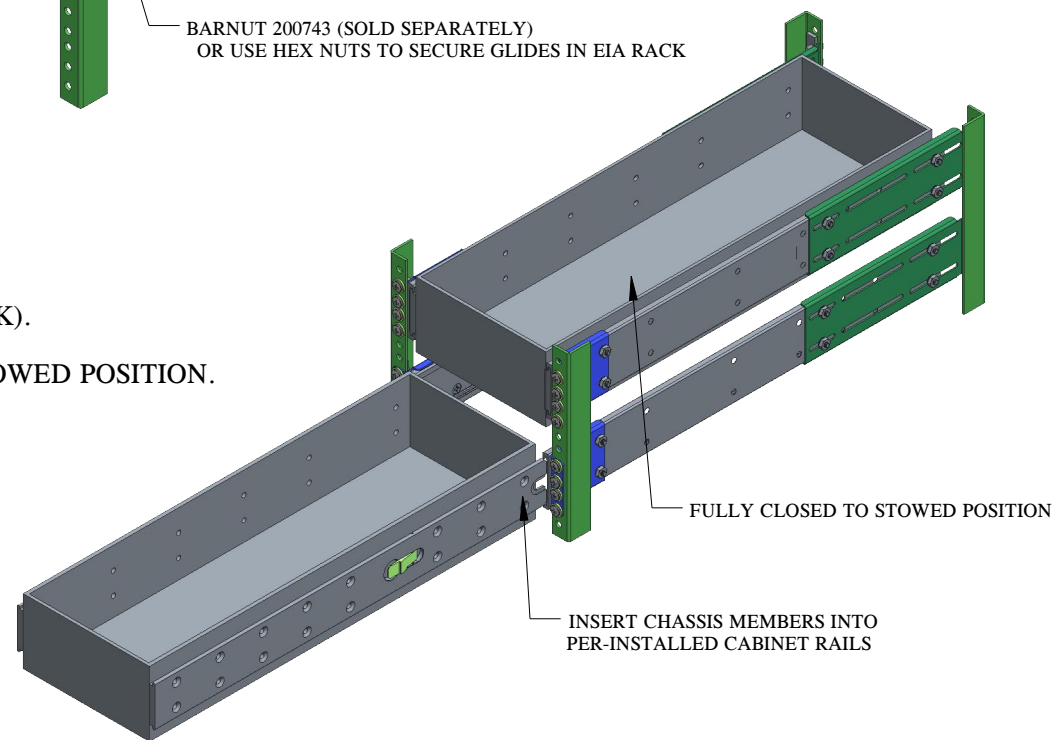

Irvine Technology Center
 250 Commerce, Suite 100
 Irvine, CA 92602
 Tel. (714) 665-4400
 Fax: (714) 368-7002
 Website: www.jonathanengr.com
 Engineer - Production - Integration/ Subassembly - Logistics
 United States - Mexico - China - Taiwan

TOLERANCES UNLESS OTHERWISE NOTED				PART NUMBER : TIG2U-280	DESCRIPTION : TRAY 2U INSTALLATION GLIDE
.XX	.XXX	ANGLES	HOLES	DATE : 05/17/18	
± .01	± .005	± 1°	± .005		
SHEET 2 OF 2				COPYRIGHT © 2012 JONATHAN ENGINEERED SOLUTIONS	