

- NOTES:**
- LEFT SLIDE AS SHOWN, RIGHT SLIDE OPPOSITE.
 - FOR BRACKETS, SEE SEPARATE SECTION.
 - SLIDE IS PROVIDED WITH LOCK TYPE "E".
LOCKS IN OPEN POSITION ONLY. (OPTIONAL)
 - MOUNTING HOLE TOLERANCE: $\pm .005$
[$\pm .13$]

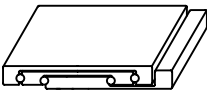

ISOMETRIC REPRESENTATION

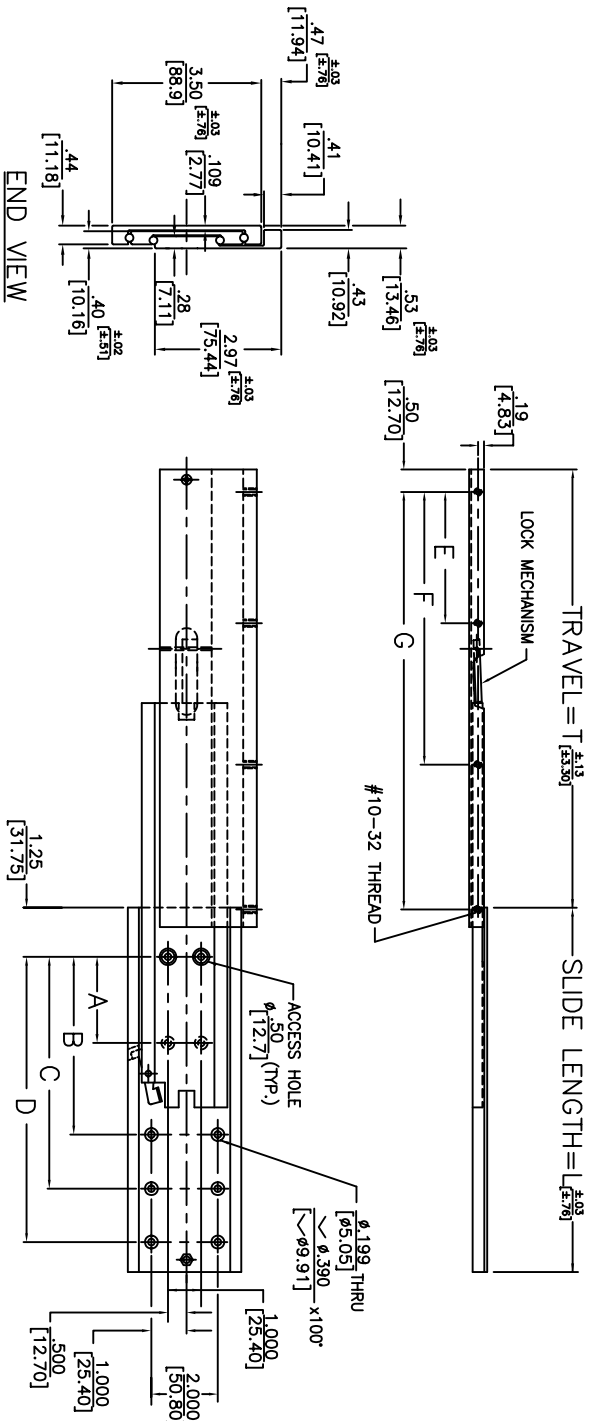

PART NO.	SERIES	SLIDE LENGTH DIM.	SLIDE TRAVEL DIM.	MOUNTING HOLE PATTERN							LOAD RATING PER PAIR	
				A	B	C	D	E	F	G		
156-10	10	9				5	8		3	6	9	240 LBS
156-12	12	228.6				127	203.2		76.2	152.4	228.6	108 KG
156-14	14	304.8				152.4	254		101.6	177.8	279.4	120 KG
156-16	16	355.6				177.8	304.8		101.6	228.6	330.2	117 KG
156-18	18	406.4				203.2	355.6		127	254	381	241 LBS
156-20	20	457.2				228.6	406.4		152.4	279.4	431.8	219 KG
156-22	22	508				254	457.2		177.8	330.2	482.6	198 LBS
156-24	24	558.8				281	508		203.2	381	524.2	183 LBS
156-26	26	609.6				304.8	558.8		228.6	431.8	575	171 LBS
156-28	28	660.4				330.2	609.6		254	482.6	626	159 LBS
156-30	30	711.2				355.6	660.4		279.4	558.8	677	147 LBS
156-32	32	762				381	711.2		304.8	630.2	728	135 LBS
156-34	34	812.8				406.4	762		330.2	701.6	779	123 LBS
156-36	36	863.6				431.8	812.8		355.6	772	830	111 LBS
156-38	38	914.4				457.2	863.6		381	843	881	99 LBS



Irvine Technology Center
410 Exchange, Suite 200
Irvine, CA 92602
Tel: (714) 665-4400
Website: www.jonathanengr.com
Engineering • Production • Integration • Subassembly • Logistics
United States • Mexico • China • Taiwan

DIMENSIONS SHOWN AS: IN. [MM]

TOLERANCE	[MM]
UNLESS OTHERWISE NOTED	
.XX	$\pm .010$
.X	$\pm .03$
XXX	$\pm .005$
.XX	[$\pm .13$]

PART NO. 156
DATE: 6/04

DESCRIPTION: ALUMINUM SERIES 156
LOAD RATING: 136-240 LBS. / 61-108 KG.